

REV.	DESCRIPTION	APPD	DATE

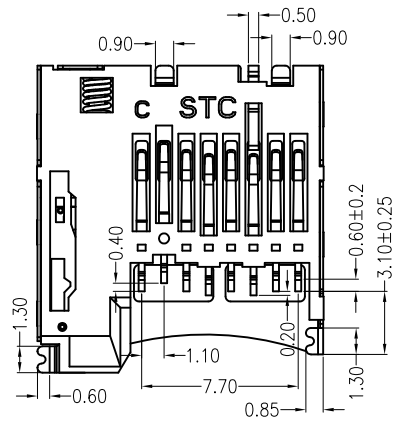

- NOTES:
- MATERIAL:  
HOUSING: HIGH TEMPERATURE THERMOPLASTIC UL94V\_0,COLOR:BLACK.  
CONTACT: COPPER ALLOYS.  
COVER: COPPER ALLOYS OR STEEL.
  - PLATING:  
UNDERPLATE: NICKEL.  
CONTACT AREA: GOLD OVER NICKEL.  
SOLDER AREA: TIN OVER NICKEL.
  - MULTIMEDIA CARD COMPATIBLE

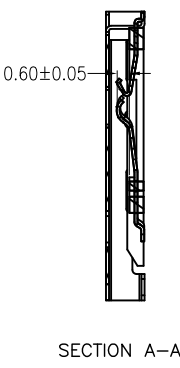
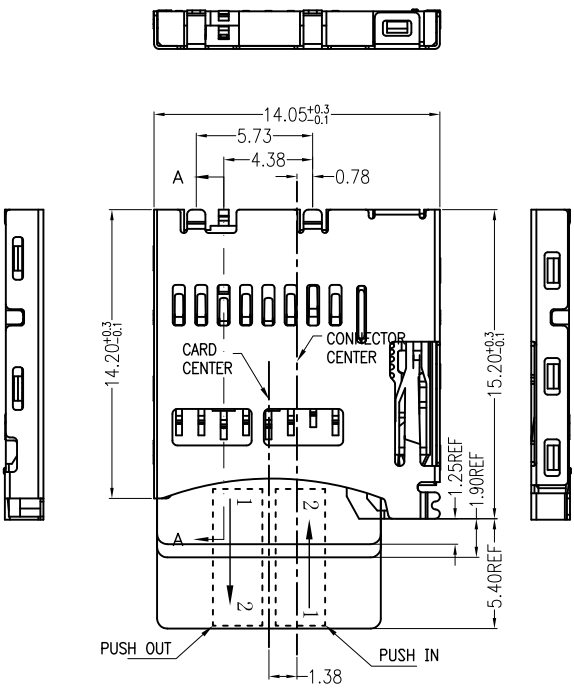
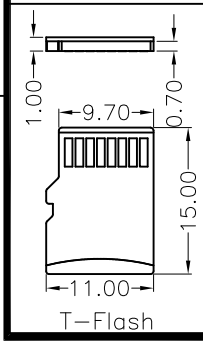
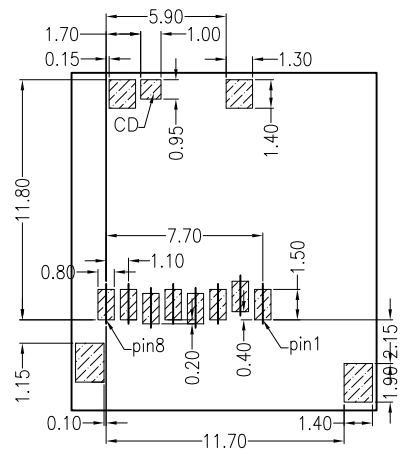
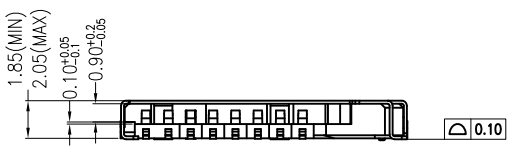
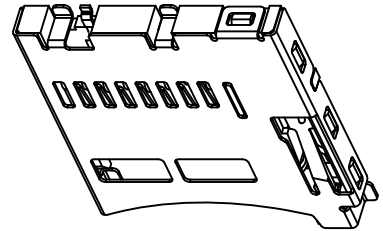

PIN NO.	NAME	YYPE	DESCRIPTION
1	DAT2	I/O/PP	DATE LINE(BIT2)
2	CD/DAT3	I/O/PP	CARD DETECT DATE LIN(BIT3)
3	CMD	PP	COMMAND RESPONSE
4	VDD	S	SUPPLY VOLTAGE
5	CLX	I	CLOCK
6	VSS	S	SUPPLY VOLTAGE GROUND
7	DATO	I/O/PP	DATE LINE(BIT0)
8	DAT1	I/O/PP	DATE LINE(DIT1)

RECOMMENDED P.C.B HOLE LAYOUT COMPONENT SIDE VIEW(TOLERANCE: +/-0.05)

PART NO: TFNF3-EBS1-1111		MATERIAL:		深圳市高塑达电子有限公司	
MODEL NO:		FINISH:			
UNIT: MM	SIZE: A4	COLOR:		TITLE: T-FLASH内焊 PUSH C Type	
TOLERANCES: X.X=±0.35 X.XX=±0.25 X.XXX=±0.15		GENERAL ANGLE: X.X=±3.0° X.XX=±2.0°		DR: 杨凯 0416'10	DWG NO: FP-100069
APP:		CHK:	APP:	SCALE: 1:1	SHEET: 1 OF 2
				REV: B/1	

REV.	DESCRIPTION	APPD	DATE

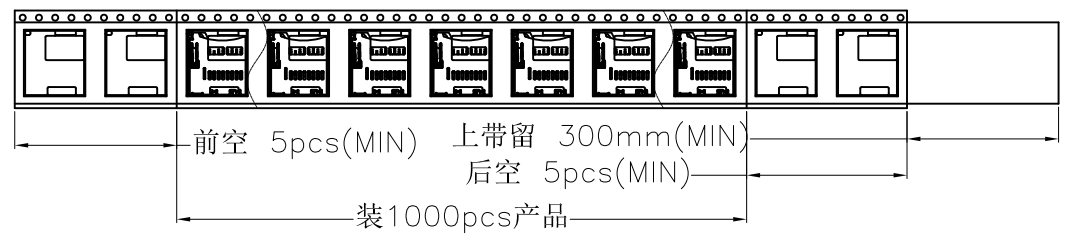
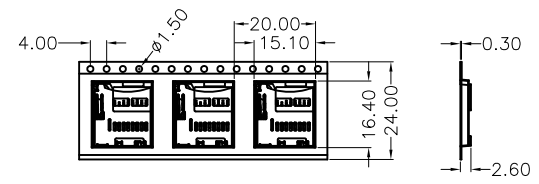

NO. 1

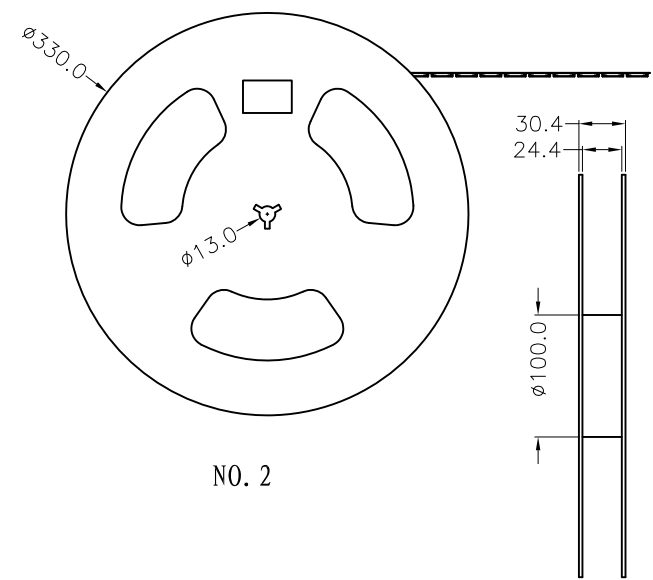

NO. 2

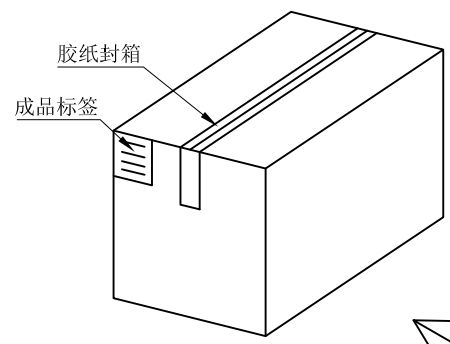
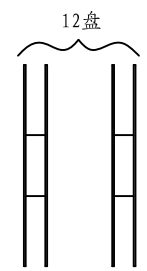

纸箱规格: 330\*330\*385

NO. 4

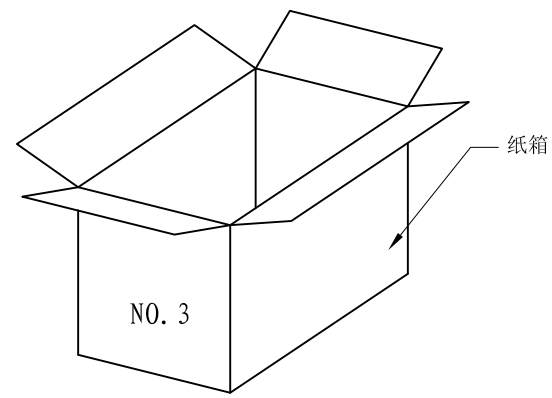

NO. 3

1. 材质要求:
- 1.1 纸箱的材质为B=; 外形尺寸为33\*33\*38.5CM;
  - 1.2 卷盘的材质为PVC, 卷盘的外形尺寸为 $\phi$ 330\*30.4;
  - 1.3 卷带的材质为PVC, 卷带的外形尺寸为20200\*24.00\*2.6mm
2. 包装要求:
- 2.1 将卷带放入包装机后, 前空5PCS, 后放产品1000PCS, 再后空5PCS; 上带留300MM长度。
  - 2.2 将包装好的产品从包装机上取下并包装好;
  - 2.3 把累叠好的12盘叠放入纸箱中共计12Kset;
  - 2.4 把包装好的成品打包封箱, 并在纸箱外贴上标签

PART NO: TFNF3-EBS1-1111		MATERIAL:		深圳市高塑达电子有限公司	
MODEL NO:		FINSH:			
UNIT: MM	SIZE: A4	COLOR:		TITLE: T-FLASH内焊 PUSH C Type	
TOLERANCES: X.X=±0.35 X.XX=±0.25 X.XXX=±0.15		GENERAL ANGLE: X.X=±3.0° X.XX=±2.0°		DR: 杨凯 0416'10	DWG NO: FP-100069
		CHK:	APP:	SCALE: 1:1	REV: B/1
				SHEET: 2 OF 2	